

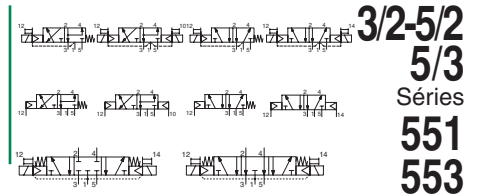

SPOOL VALVES

pilot operated or air operated, spool type
single/dual solenoid or air
aluminium body, "NAMUR" style, 1/4 - 1/2



FEATURES

- The solenoid operated spool valves have threaded port connections and NAMUR interface
- The same spool valve can be adapted for 3/2 NC or 5/2 functions for controlling double-acting and single-acting actuators
- All the exhaust ports of the spool valve are connectable, providing better environmental protection. Particularly recommended for sensitive areas, such as clean rooms, and applications in the pharmaceutical and food processing sectors
- The valves offer environmental protection against the ingress of liquids, dusts or other foreign matter (environmentally-protected construction)
- The monostable spool valves in conformity with IEC 61508 Standard (2010 route 2_H version) have TÜV (551 series) and EXIDA (551-553 series) certified with integrity levels: SIL 2 for HFT = 0 / SIL 3 for HFT = 1
- The solenoid valves satisfy all relevant EU directives

GENERAL

Differential pressure
Flow (Qv at 6 bar)

2 - 10 bar [1 bar = 100 kPa]
l/min (ANR)
1/4 | 1/2
700 | 3000

fluids (*)	temperature range (TS)	seal materials (*)
air, inert gas, filtered	-25°C to +60°C	NBR (nitrile) + PUR (polyurethane)

MATERIALS IN CONTACT WITH FLUID

(*) Ensure that the compatibility of the fluids in contact with the materials is verified

Body, end cover Aluminium, black anodized
End cover (spring return) Glass fibre filled PA
Spool valve internal parts Zamak, stainless steel, POM, aluminium
Seals NBR + PUR
Core tube Brass
Core and plugnut Stainless steel
Shading coil Copper

ELECTRICAL CHARACTERISTICS

Coil insulation class F
Connector Spade plug (cable Ø 6-8 mm or Ø 6-10 mm)
Connector specification EN 175301-803, 11 mm, industry standard form B (type 01) or ISO 4400 / EN 175301-803, form A (type 02) IEC 335
Electrical safety
Electrical enclosure protection Moulded IP65 (EN 60529)
Standard voltages DC (=): 24V - 48V
 (Other voltages and 60 Hz on request) AC (~): 24V - 48V - 115V - 230V / 50 Hz

prefix option	power ratings				operator ambient temperature range (TS) (C°)	replacement coil		type ⁽¹⁾
	inrush ~ (VA)	holding ~ (W)		hot/cold = (W)		~	=	
		(VA)	(W)					
SC	6	3,5	2,5	2,5 / 3	-25 to +60	230 V/50 Hz	24 V DC	01
SC	15	7	5	4 / 5	-25 to +60	400727-117	400727-185	02

⁽¹⁾ Refer to the dimensional drawings on the following page

SPECIFICATIONS

[Configurator - CAD Files](#)

pipe size	orifice size	flow coefficient Kv		operating pressure differential (bar)			power coil (W)		catalogue number	options		
				min.	max. (PS)		~	=		maintained	man. operator	
					air (*)	~						
G	(mm)	(m³/h)	(l/min)						~/=			
3/2 NC - 5/2 - Solenoid air pilot operated - spring return (monostable)												
1/4	6	0,6	10	2	10	10	2,5	3	SCG551A001 SCG553A001	MS	-	-
1/2	13	2,49	41,5	2	10	10	5	5		MS	-	-
3/2 NC - 5/2 - Solenoid air pilot operated and return (bistable)												
1/4	6	0,6	10	2	10	10	2,5	3	SCG551A002 SCG553A002	MS	-	-
1/2	13	2,49	41,5	2	10	10	5	5		MS	-	-
5/3 - W1 - pressure held, solenoid air pilot and return												
1/4	6	0,6	10	2	10	10	2,5	3	SCG551A065 SCG553A065	MS	-	-
1/2	13	2,49	41,5	2	10	10	5	5		MS	-	-
5/3 - W3 - pressure released, solenoid air pilot and return												
1/4	6	0,6	10	2	10	10	2,5	3	SCG551A066 SCG553A066	MS	-	-
1/2	13	2,49	41,5	2	10	10	5	5		MS	-	-
3/2 NC - 5/2 - Solenoid air pilot operated spring return (monostable), certified IEC 61508 Functional Safety data												
1/4	6	0,6	10	2	10	10	2,5	3	SCG551A001SL SCG553A001SL	-	-	-
1/2	13	2,49	41,5	2	10	10	5	5		-	-	-

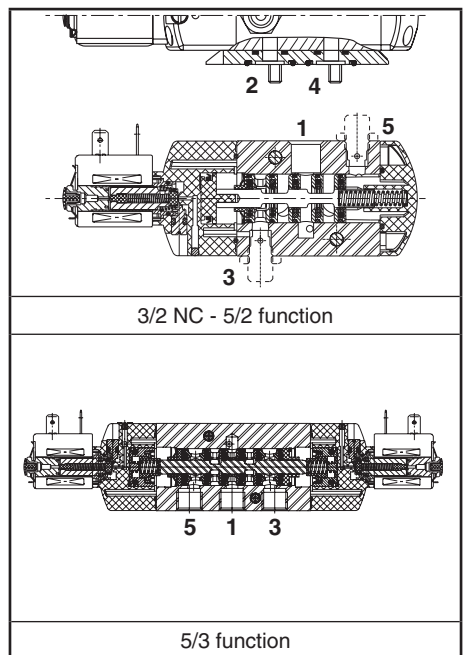

AIR OPERATED AND OPTIONS

- Versions (Type 03): - pilot air operated, spring return, catalogue numbers: **G551A101 / G551A101SL** (1/4); **G553A101 / G553A101SL** (1/2)
- pilot air operated and return, catalogue numbers: **G551A102** (1/4); **G553A102** (1/2)
- Suffix **"MF"** (air operated only, low temperature version, -40°C)
- Suffix **"GD"** (air operated only, ATEX 2GD c)
- Explosionproof enclosures for use in zones 1/21-2/22, categories 2-3 to ATEX Directive 2014/34/EU (see "Explosionproof solenoids" section)
- Valves equipped with exhaust reducers G 1/8 (3/2 NC-5/2, series 551), suffix **MMS**
- Set of stainless steel mounting screws (series 551), catalogue number **97802212**
- Set of two G 1/8 exhaust reducers (series 551), catalogue number **88100344**
- Other pipe connections are available on request
- Plug with visual indication and peak voltage suppression or with cable length of 2 m (see Solenoids, Coils & Accessories section)

INSTALLATION

- The valves can be mounted in any position without affecting operation
- 3/2 NC-5/2 spool valve supplied with one or two interface plates with NAMUR mating surfaces. Depending on function (3/2 NC or 5/2), position the plate (series 551) or one of the two plates (series 553) on the spool valve body before installing on actuator
- Do not connect the pressure supply to the exhaust port 3. The "environmentally-protected" construction is not adapted for NO function. Contact us for function available in specific version
- Dowel pin (if necessary), bolts and gaskets are standard supplied
- It is necessary to connect pipes or fittings to the exhaust ports to protect the internal parts of the spool valve and its pneumatic operator if used outside or in harsh environments (dusts, liquids etc.)
- IEC 61508 Functional Safety (suffix SL). Check temperature range of valve body and solenoid for suitability. For probability of failure, contact us
- Threaded pipe connection is standard: G = G (ISO 228/1)
- Valves with suffix "SL" are supplied with specific exhaust protectors
- Installation/maintenance instructions are included with each valve

ACCESSORIES

series	pipe size	exhaust protector (stainless steel)
551	G 1/8	34600418 ⁽¹⁾
551 (W1/W3)	G 1/4	34600419
553	G 1/2	34600479 ⁽¹⁾
551-553	M5	34600484 ⁽¹⁾

⁽¹⁾ Supplied with suffix "SL"

ORDERING EXAMPLES:

SC	G	551	A	001	MS	230V / 50 Hz
SC	G	551	A	001	SL	24V / DC
SC	G	553	A	002		115V / 50 Hz
		G	551	A	101	SL

prefix: SC
 pipe thread: G
 basic number: 551 A 101
 voltage: 230V / 50 Hz
 suffix: SL

DIMENSIONS (mm), WEIGHT (kg)



TYPE 01

Prefix "SC" Solenoid
Epoxy moulded
IEC 335 / DIN 43650
IP65

551A001/A001MS/A001SL/A002/A002MS

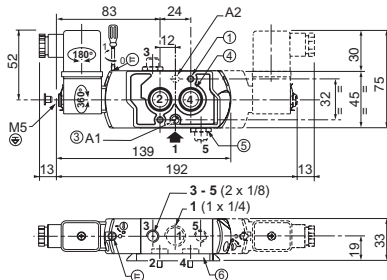

**551A065/A065MS/A066/A066MS
(W1 - W3)**

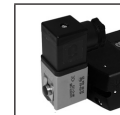
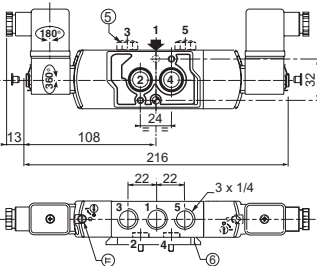

TYPE 02

Prefix "SC" Solenoid
Epoxy moulded
IEC 335 / ISO 4400
IP65

**553A001/A001MS/A001SL/A002/A002MS
553A065/A065MS/A066/A066MS**

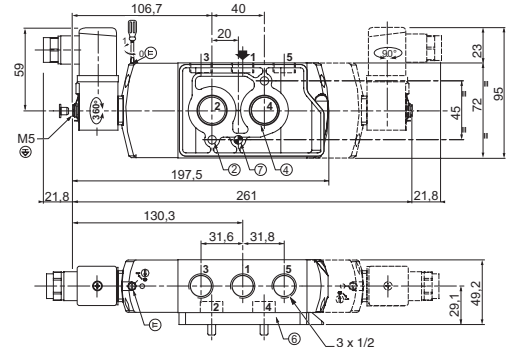

TYPE 03

No prefix
Air operated version

G551A101/A102

G553A101/A101SL/A102

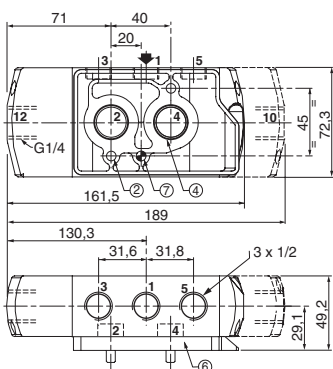
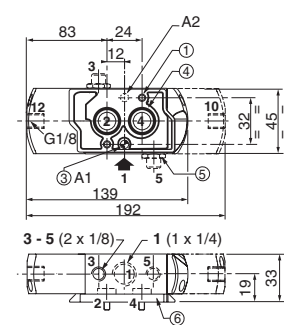

- 1 2 mounting holes: 5,3 mm dia. (Spotfacing: 9 mm dia., depth 5 mm)
- 2 2 mounting holes: 6,5 mm dia. (Spotfacing: 11 mm dia., depth 6 mm)
- 3 One 5 mm dia. hole for dowel pin:
- in position A1: 3/2 NC function plate
- in position A2: 5/2 function plate
- 4 2 O-ring seals (supplied)
- 5 Exhaust reducer (G 1/8, 3/2 NC-5/2, series 551) or exhaust protector
- 6 Interface plate

weight ⁽²⁾ (kg)	type 01		type 02		type 03	
	3/2-5/2	5/3	553	551	553	553
monostable.	0,34	-	0,90	0,31	0,85	
bistable	0,46	0,45	1,20	0,41	1,11	

⁽²⁾ Incl. coil(s) and connector(s).

All leaflets are available on: www.asco.com



SOLENOID VALVES

pilot operated, spool type
single/dual solenoid (mono/bistable function)
aluminium body, "NAMUR" style, 1/4 - 1/2

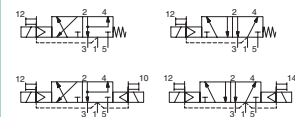

3/2-5/2

Series
551
553

FEATURES

- The solenoid operated spool valves have threaded port connections and NAMUR interface
- The same spool valve can be adapted for 3/2 NC or 5/2 functions for controlling double-acting and single-acting actuators
- All the exhaust ports of the spool valve are connectable, providing better environmental protection. Particularly recommended for sensitive areas, such as clean rooms, and applications in the pharmaceutical and food processing sectors
- The valves offer environmental protection against the ingress of liquids, dusts or other foreign matter (environmentally-protected construction)
- Solenoid pilot valve with spade-plug connector type EN 175301-803, industry standard form C, with 9,4 mm spacing. Versions with M12 connection
- Solenoid pilot valve, CNOMO size 15 interface, with or without integral LED and electrical protection. LED indicator visible from 3 sides
- The monostable spool valves in conformity with IEC 61508 Standard (2010 route 2_H version) have TÜV (551 series) and EXIDA (551-553 series) certified with integrity levels: SIL 2 for HFT = 0 / SIL 3 for HFT = 1
- The solenoid valves satisfy all relevant EU directives

GENERAL

Differential pressure
Flow (Qv at 6 bar)

2 - 10 bar [1 bar = 100 kPa]
l/min (ANR)

1/4	1/2
700	3000

Pilot mounting interface surface

ISO 15218 (CNOMO E06.36.120N, size 15)

fluids (*)	temperature range (TS)	seal materials (*)
air, inert gas, filtered	-25°C to +40°C	NBR (nitrile) + PUR (polyurethane)

MATERIALS IN CONTACT WITH FLUID

(*) Ensure that the compatibility of the fluids in contact with the materials is verified

Body	Aluminium, black anodized
End cover (spring)	Glass fibre filled PA
Interface plates	Glass fibre filled PA
Spool valve internal parts	Zamak, stainless steel, POM, aluminium
Pilot body	PARA
Pilot internal parts	POM, PET, stainless steel and brass
Pneumatic interface seal	TPE

ELECTRICAL CHARACTERISTICS

Coil insulation class	F
Connector (type 05)	Spade plug (cable Ø 4-6 mm)
Connector specification	Type 05: DIN 43650, 9,4 mm, form C
Connection	Type 07: M12 (CNOMO E03.62.520.N)
Electrical safety	IEC 335
Electrical enclosure protection	Moulded IP65 [05] or IP67 [07] (EN 60529)
Standard voltages	DC (=): 24V
(Other voltages and 60 Hz on request)	AC (~): 24V-115V-230V / 50 Hz (prefix CFSC)

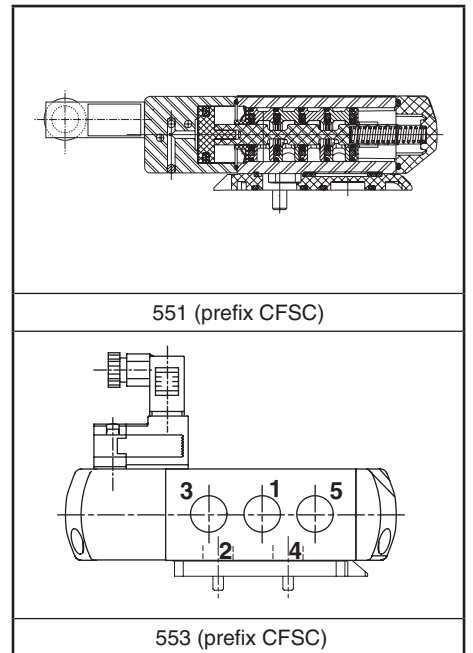

prefix option	power ratings				operator ambient temperature range (TS) (C°)	voltage		type ⁽¹⁾			
	inrush ~	holding ~		hot/cold =		~	=				
	(VA)	(VA)	(W)	(W)		(V)	(V)				
CFSC	1,4	1,2	1,1	1/1,2	-25 to +60	24-115	24	05			
	1,8 ⁽²⁾	1,6 ⁽²⁾	1,5 ⁽²⁾	1,15/1,35 ⁽²⁾							
	2,1	1,6	1,5	-					-25 to +60	230	-
	2,5 ⁽²⁾	2 ⁽²⁾	1,9 ⁽²⁾	-					-25 to +50	-	-
CFVT ⁽³⁾	-	-	-	1,15/1,35	-25 to +60	-	24	07			

⁽¹⁾ Refer to the dimensional drawings on the following page.

⁽²⁾ Values with LED indicator and protection, use TPL 20674.

⁽³⁾ Supplied with LED indicator and protection.

SPECIFICATIONS

[Configurator - CAD Files](#)

pipe size	orifice size	flow coefficient Kv		operating pressure differential (bar)			power coil (W)		catalogue number		options		
									connector EN 175301-803 (9,4 mm) (type 05)	M12 (type 07)	maintained man. operator	impulse man. operator	-
3/2 NC - 5/2 - Solenoid air pilot operated - spring return (monostable)													
1/4	6	0,6	10	2	10	10	1,1..1,5	1,2	CFSCG551C501	-	MS	MO	-
							-	1,35	-	CFVTG551C501	MS	MO	-
1/2	13	2,49	41,5	2	10	10	1,1..1,5	1,2	CFSCG553A501	-	MS	MO	-
							-	1,35	-	CFVTG553A501	MS	MO	-
3/2 NC - 5/2 - Solenoid air pilot operated and return (bistable)													
1/4	6	0,6	10	2	10	10	1,1..1,5	1,2	CFSCG551C502	-	MS	MO	-
							-	1,35	-	CFVTG551C502	MS	MO	-
1/2	13	2,49	41,5	2	10	10	1,1..1,5	1,2	CFSCG553A502	-	MS	MO	-
							-	1,35	-	CFVTG553A502	MS	MO	-

SPECIFICATIONS

pipe size	orifice size	flow coefficient Kv		operating pressure differential (bar)				power coil (W)		catalogue number		options	
				min.	max. (PS)		connector EN 175301-803 (9,4 mm) (type 05)			M12 (type 07)	maintained man. operator	impulse man. operator	
					air (*)								
G	(mm)	(m ³ /h)	(l/min)		~	=	~	=	~/=	=			
3/2 NC - 5/2 - Solenoid air pilot operated spring return (monostable), certified IEC 61508 Functional Safety data													
1/4	6	0,6	10	2	10	10	1,1..1,5	1,2	CFSCG551C501SL	-	-	MO	
							-	1,35	-	CFVTG551C501SL	-	MO	
1/2	13	2,49	41,5	2	10	10	1,1..1,5	1,2	CFSCG553A501SL	-	-	MO	
							-	1,35	-	CFVTG553A501SL	-	MO	

OPTIONS

- Explosionproof enclosures for use in zones 1/21-2/22, categories 2-3 to ATEX Directive 2014/34/EU (see "Explosionproof solenoids" section)
- LED and protection, prefixes CFSC / CFSD, use TPL number: TPL 20674 (e.g.: CFSDXG551C505TPL20674)
- Straight M12 connector: with 5 m cable length (catalogue number **88130212**)
- Valves equipped with exhaust reducers G 1/8 (3/2 NC-5/2, series 551), suffix **MMS**
- Set of stainless steel mounting screws (series 551), catalogue number **97802212**
- Set of two G 1/8 exhaust reducers (series 551), catalogue number **88100344**
- Versions with spade-plug connector type ISO 15217/DIN 43650 form C with 8 mm spacing or with cable ends: contact us
- Other pipe connections are available on request
- Plug with visual indication and peak voltage suppression or with cable length of 2 m (see Solenoids, Coils & Accessories section)

INSTALLATION

- The valves can be mounted in any position without affecting operation
- 3/2 NC-5/2 spool valve supplied with one or two interface plates with NAMUR mating surfaces. Depending on function (3/2 NC or 5/2), position the plate (series 551) or one of the two plates (series 553) on the spool valve body before installing on actuator
- Do not connect the pressure supply to the exhaust port 3. The "environmentally-protected" construction is not adapted for NO function. Contact us for function available in specific version
- Dowel pin (if necessary), bolts and gaskets are standard supplied
- It is necessary to connect pipes or fittings to the exhaust ports to protect the internal parts of the spool valve and its pneumatic operator if used outside or in harsh environments (dusts, liquids etc.)
- IEC 61508 Functional Safety (suffix SL). Check temperature range of valve body and solenoid for suitability. For probability of failure, contact us
- Threaded pipe connection is standard: G = G (ISO 228/1)
- Valves with suffix "SL" are supplied with specific exhaust protectors
- Installation/maintenance instructions are included with each valve

ACCESSORIES

series	pipe size	exhaust protector (stainless steel)
551	G 1/8	34600418 ⁽¹⁾
553	G 1/2	34600479 ⁽¹⁾
551-553	M5	34600484 ⁽¹⁾

⁽¹⁾ Supplied with suffix "SL"

ORDERING EXAMPLES:

CFSC	G	551	C	501	230V / 50 Hz
CFSC	G	551	C	501	SL 115V / 50 Hz
CFVT	G	553	A	502	MS 24V / DC
CFSC	G	551	C	501	SLMO 230V / 50 Hz

prefix — pipe thread — basic number — voltage — suffix

DIMENSIONS (mm), WEIGHT (kg)

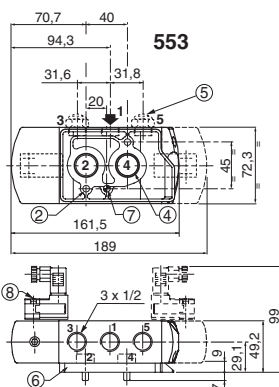
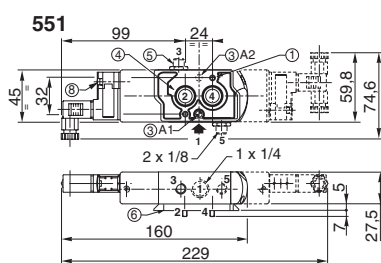

Configurator - CAD Files

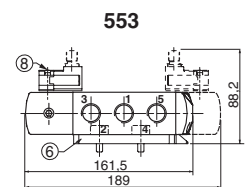
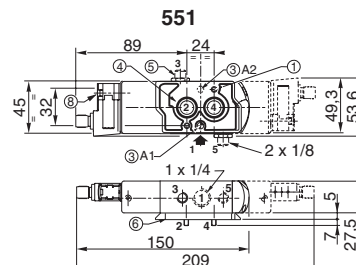

2 mounting holes:

- ① 5,3 mm dia. (Spotfacing: 9 mm dia., depth 5 mm)
- ② 6,5 mm dia. (Spotfacing: 11 mm dia., depth 6 mm)
- ③ One 5 mm dia. hole for dowel pin:
 - in position A1: 3/2 NC function plate
 - in position A2: 5/2 function plate
- ④ 2 O-ring seals (supplied)
- ⑤ Exhaust reducer (G 1/8, series 551) or exhaust protector
- ⑥ Interface plate
- ⑦ One 6,5 mm dia. hole for dowel pin, position for 3/2 NC or 5/2 function plate
- ⑧ Manual operator location

type	prefix option	weight ⁽²⁾			
		monostable		bistable	
05	CFSC	0,34	1	0,39	2,08
07	CFVT	0,36	1,02	0,43	2,12

⁽²⁾ Prefix CFSC: including connector(s).

All leaflets are available on: www.asco.com

60 - Pneumatic Valves (3/2 - 5/2 - NAMUR)